

PATIO COMFORT

**NATURAL GAS FUELED OUTDOOR PATIO HEATER
MODEL NPC05**

ASSEMBLY INSTRUCTIONS CARE, USE, AND SAFETY MANUAL

FOR YOUR SAFETY!

Do not store or use gasoline or other flammable vapors or liquids in the vicinity of this or any other appliance.

IMPORTANT!

Please read these assembly instructions carefully before attempting to assemble, use, or service this product. Please keep this manual for your future reference. If you have any questions, please feel free to call us at 949-474-3070 Monday through Friday 7AM to 4PM Pacific Time.

General Hazard Warning:

Improper installation, adjustment, alteration, service or maintenance of this product can cause injury or property damage. Please read the installation, operating, and maintenance instructions thoroughly before installing or servicing this appliance.

Please read all operating instructions before using and operating this appliance.

Always follow the correct lighting and usage procedures.

Please handle metal parts with care to avoid injury. Please follow all steps as outlined.

Never allow children to use this product!



WARNING:

This product is for Outdoor Use Only

Revised 7-06-05 gfs

1. The assembly and installation of this appliance must conform with local codes or in the absence of local codes, to the National Fuel Gas Code ANSI Z223.1-1988.
2. There must be adequate clearances around all air openings into the combustion chamber. You must also have adequate clearances from combustible materials and an adequate air supply going to the heater. See page 19 for specific clearances from combustibles.
3. ***A HIGH QUALITY NATURAL GAS REGULATOR, DOUBLE QUICK DISCONNECT COUPLER, AND 12 FOOT HOSE SET WITH SAFETY SHUT OFF VALVE HAS BEEN PROVIDED FOR YOUR SAFETY AND CONVENIENCE. THE REGULATOR HAS BEEN PRE SET TO OPERATE YOUR HEATER AT 4.5" WATER COLUMN. ALL OF THESE COMPONENTS MUST BE USED FOR THE SAFE OPERATION OF YOUR HEATER. DO NOT ATTEMPT TO REPLACE, MODIFY, OR ALTER THE COMPONENTS PROVIDED WITH YOUR HEATER.***
4. The maximum inlet supply pressure CANNOT EXCEED 10" W.C. natural gas.
5. Test all fittings and connections with a soapy solution prior to use. Never use an open flame or open flame device.
6. Certain items or materials when stored under the heater or too close to the heater head will be subject to radiant heat that could cause these items to be damaged.
7. Please review carefully and follow all assembly instructions as shown from pages 11 – 16. If you do not understand any of these instructions or feel uncomfortable assembling your unit please call your selling dealer or call us directly at 949-474-3070.
8. Please carefully inspect the rubber hose included with the unit before each use. Be sure there are no visible cracks, damage, abrasion, or other signs of visible wear. If the hose, quick connect couplers, or main shut-off valve appear to have any problem whatsoever they should be replaced with a genuine Patio Comfort replacement part.
9. When using your heater with 12-foot hose please be sure that the hose is placed in a manner where it cannot be damaged or positioned in a way that someone might trip over it.
10. Please follow the lighting and shutdown instructions on page 20- 21 to insure safe use.

Please note the following very important safety precautions:

- !!! Children and adults should be alerted to the hazards of high surface temperatures of the main burner and reflector and should stay away from these areas.**
- !!! Children should be carefully supervised when near the heater. This heater is not a toy and children should not be allowed to push, climb on, or swing on the heater. THESE ACTIONS COULD CAUSE SERIOUS INJURY, PROPERTY DAMAGE, OR DEATH.**
- !!! Clothing or other flammable materials should not be hung from the heater and/or placed near the heater during operation.**
- !!! Installation and repair of the heater should be done by a qualified service technician. The heater should be visually inspected before each use and at least annually by a qualified service technician. Certain weather conditions such as being near the ocean, dusty areas, areas with high humidity, areas with high wind conditions, and heavy use, may require more frequent cleaning or maintenance. When in doubt call a qualified service technician. It is imperative that the control compartment, burner system, and circulating air passages of the heater be kept clean.**
- !!! Any part, sub-assembly, or component removed for cleaning or maintenance must be properly re-installed before using the heater.**

Some basic use and maintenance instructions:

- !!! Be sure to keep the area where the appliance is being used free from combustible materials, gasoline, and other flammable materials.**
- !!! Please be sure there are no obstructions near the heater head.**
- !!! The appliance is operating properly when there is a nice cherry red glow (seen better at night) coming from the emitter grid starting two to three inches from the bottom of the emitter grid. Wind gusts will affect and possibly disrupt the glow and flame pattern. The heater should not be operated in windy conditions over 5 – 7 MPH. If you can protect the heater from wind gusts it will operate far more efficiently. Operating the unit in severe wind or dusty conditions will affect the burning characteristics, may create soot on the emitter grid and burner, and possibly clog the pilot or main burner orifices.**
- !!! The heater post, base, and reflector, may be cleaned with basic soap and water and mild household cleaning products, car wax, or commercially available stainless steel cleaners. Never attempt to clean the emitter grid radiant with any cleaning solutions or abrasive materials. Never spray the emitter grid or heater head assembly with water or other liquids, as it will damage the radiant, burner, valve, and ignition system. These parts are constructed of commercial quality stainless steel and brass and require no cleaning. Occasionally, you can gently brush the emitter grid with a small non-abrasive brush to remove excess soot that may have accumulated on the emitter. If the emitter grid shows sooting you may have to remove the emitter grid and clean the burner head as well.**
- !!! It is absolutely imperative that this heater only be used OUTDOORS and in a well-ventilated space and shall not be used in a building, garage, motor vehicle, recreational vehicle, boat, tent, or other enclosed areas. This is an un-vented heating product and creates by-products of combustion that can cause injury and possibly death.**

The preceding pages attempt to highlight only the most important safety aspects and guidelines for using your natural gas fueled *Patio Comfort* heater. We have made every effort to thoroughly address all safety, assembly, lighting, and use issues for this product in the manual to follow. We strongly encourage that you read and understand the materials contained in the manual before using your heater. If you have any questions whatsoever regarding the safe assembly or use of your heater please call your *Patio Comfort* Dealer or Authorized Distributor or call us directly at 949-474-3070.

Thank you very much for purchasing a *Patio Comfort* *Patio* heater. This manual contains very important information detailing the proper assembly, operation, and maintenance of this product. This product has been designed with the latest in safety technology, but it is important to remember that this is a heating appliance and some of the surfaces are extremely hot to the touch and can cause bodily injury. Important safety information is presented throughout this manual for your safety and that of your family. We have designed this product to provide you with many years of outdoor comfort when operated and maintained properly. If you have questions as to the assembly or safe operation of the heater please call your selling dealer or call us directly 949 474-3070 Monday through Friday & 7 AM to 4 PM Pacific Coast Time.

Table of Contents

	PAGE #
BASIC SAFETY AND OPERATIONAL DATA	1
TABLE OF CONTENTS	5
TECHNICAL DATA	6
FUNCTION OF HEATER	6
ASSEMBLY TIPS	6
PARTS DIAGRAM/DESCRIPTION (HEAD ASSEMBLY)	8
PARTS DIAGRAM/DESCRIPTION (SUB-ASSEMBLY)	9
TOOLS NEEDED	10
FASTENER IDENTIFICATION	10
ASSEMBLY INSTRUCTIONS – STEP 1	11
ASSEMBLY INSTRUCTIONS – STEP 2 TO 4	12
ASSEMBLY INSTRUCTIONS – STEP 5 TO 7	13
ASSEMBLY INSTRUCTIONS – STEP 8 TO 9	14
ASSEMBLY INSTRUCTIONS – STEP 10 TO 12	15
ASSEMBLY INSTRUCTIONS – STEP 13 TO 14	16
INFORMATION ON NATURAL GAS SUPPLY	18
PLACEMENT OF HEATER	19
LIGHTING INSTRUCTIONS	20
HEATER STORAGE AND INSECT WARNING	21
CLEANING AND MAINTENANCE	22
TROUBLE SHOOTING GUIDE	23
WARNINGS AND SAFETY POINTS	24
SERVICE AND WARRANTY INFORMATION	26
LEGAL RIGHTS	27
WARRANTY REGISTRATION FORM	28

Technical Data: Model NPC05

This unit is designed and configured for use with Natural Gas Only.

Fuel: Natural Gas

Heating: Each *Patio Comfort* heater will cast a 10-12 foot circle of sun like radiant heat. Heat output will vary based on "wind chill" factor, outside air temperatures, altitude, prevailing wind conditions, and location of heater.

Pressure: The unit is equipped with an external Natural Gas Regulator (supplied with heater) preset to **4.5 Inches Water Column. This specially designed regulator, fuel line, and natural gas fuel source shut-off kit must be used with this appliance.** Hose, couplers, and shut-off components are CSA (AGA) approved and should meet all local codes and ordinances in U.S. and Canada. Check your local codes agency if you have any questions. Complies with ANSI Z 21.54

Maximum: pressure Natural Gas ½ psig

**Minimum inlet supply pressure 6.0" W.C.
Manifold Pressure: 4.5"**

BTU Input/Hour 41,000 BTU Input /Hour

Main Burner Orifice Size: 0.12 Dec. In.

Weight: 57 Pounds

Overall Height: 90 inches 228 cm

Reflector Diameter: 34 inches or 86 cm

Ignition System: Push Button Piezo with Pilot Flame

Fasteners: Stainless Steel

Materials: Reflector: Anodized Aluminum

Stainless Steel Heaters: Major Components: Series 304 Stainless Base: socket, 66" post, emitter grid, decorative sleeve, base cover plate, and burner. Ballast Weight Powder Coated Cast Iron

Other features: 100% Safety Shut Off Valve
No Electrical Connections Required
Constant Pilot

**12 Foot MB Sturgis Steel lined Hose with integral ball valve, quick disconnect coupling with thermal protection, and a 3/8" fully interlocking strip-wound hose/male plug x 3/8" female quick disconnect coupling.
MAXITROL NG Regulator @ 4.5" W.C. included**

Function of Heater

Infrared heaters utilize virtually 100% of the fuel/energy they consume to produce clean draft-free warmth. **Infrared heaters do not waste precious energy by trying to heat the air.**

Infrared heat works like the radiant rays of the sun and will directly heat objects near them such as people, tables, chairs who in turn will absorb the heat and reflect it. The push button Piezo ignition system is used to light the pilot flame first. After the thermocouple device allows gas to flow to the main burner head you may then safely engage the main burner system by turning valve control knob to "ON" Setting.

After the main burner is lit the burner will radiate heat in a 360-degree circle. The circle of warmth will vary dependent on outdoor temperatures, wind chill factor, area protection, and other variables. The average heating area is approximately a 10-foot ring of warmth. The reflector will return upwardly radiated heat downwards. On first use please allow heater to burn a few minutes to burn off machining oils used in the production of the heater.

Please note: Upon first using the heater, not using the heater for an extended period, or after re-attaching the 12 foot hose to the unit, it may be necessary to depress the control knob at the "PILOT" setting up to two minutes to purge the air in the hose and fuel lines before the PILOT flame will ignite. Please be patient, this is all part of the safety system that has been designed for your protection.

Assembly Tips

For your convenience and safety the *Patio Comfort* outdoor patio heater has been almost completely Assembled. The burner head and valve assembly have been fire tested for added safety.

Assemble all nuts and bolts loosely at first. Tighten all connections after the completion of the assembly process. This eases your work and increases the overall stability of the appliance. **Before using the heater please be sure to check all connections with a solution of soap and water.** More on this later in the instructions. Never use a flame to check for leaks!

When starting the assembly process please take all of the parts out of the boxes and check if anything is missing. Please check parts with the following parts breakdown. Even though we exercise extreme quality control procedures occasionally we will have a missing part or a part may have been damaged in

transit. If anything is missing, please contact your local *Patio Comfort* dealer or call us directly at 949-474-3070. We will immediately help you. The same holds true on any questions you might have on assembly or operation. When in doubt, please ask. We're at your service.

Notes:

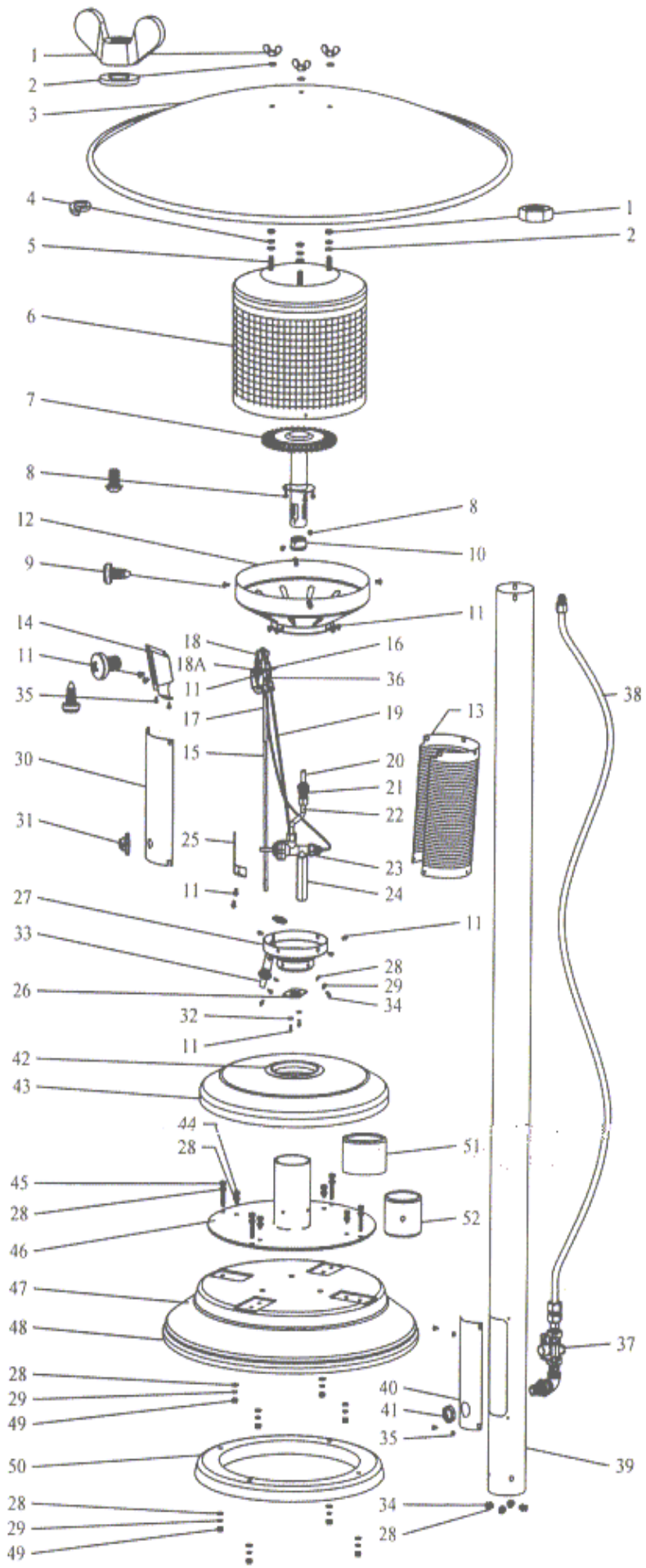

**OUTDOOR GAS HEATER MODEL NPO
DIAGRAM REPAIR PARTS**

KEY	PART#	DESCRIPTION
8	1028	FLAT WASHER 6 MM DIA. SS
9	1029	LOCK WASHER 6 MM DIA. SS
10	1030	FACEPLATE FOR LIGHTING INSTRUCTION
11	1031	KNOB
12	1032	FLAT WASHER 5 MM DIA. SS
13	1033	PIEZO IGNITER/SPECIFIC NUT
14	1034	PAN HEAD SCREW M6 X 12MM
15	1035	SELF-TAPPING PAN HEAD SCREW FOR PILOT SHIELD M4 X 8 MM
16	1036-05	PILOT ORIFICE
17	1137	REGULATOR FITTING ASSY.
18	1138	54" FUEL HOSE ASSY
19	4139	POST /ACCESS HOLE SS
	5139	PAINT POST /ACCESS HOLE

You will need the following tools and materials to assemble the heater:

Teflon tape or gas sealant/pipe compound
Adjustable crescent wrench or socket Driver

Standard Phillips Head #3 screw driver
Channel Locks or Pliers-Minimum 1 ½" capacity
Soapy water solution for leak testing

Do Not Use any Teflon tape or other sealants when connecting flare-to-flare connections. All male pipe thread connections will require Teflon tape or other approved sealant. Teflon tape FOR NATURAL GAS works the best and is the easiest to use.

Fastener Identification

Heater

8 – Pan Head Screws M6 x 12 mm S/S
8– Flat Washers 6mm dia.
8– Lock Washers 6 mm dia
4 Pan Head Self-taping Sheet Metal Screws.

Make sure there are no cracks in the hose, cuts, or other abrasions, which might cause a fuel leak. If the hose, couplers, heater valve, or natural gas regulator assembly is found to be faulty in any way **DO NOT USE** the appliance. Call your authorized *Patio Comfort* dealer and only use genuine *Patio Comfort* replacement parts. Using improper parts may damage the product or cause physical or property damage.

PLEASE NOTE: The proper assembly of this heater requires basic mechanical skills. Proper assembly and installation is the responsibility of the customer. All repair or services should be done by a qualified gas appliance technician.

Warning!!!

Improper installation, adjustment, alteration, service, or maintenance can cause property damage, injury or death. Read the assembly, installation, operating, and maintenance instructions thoroughly before use, installing or servicing the appliance. This heater is for outdoor use only.

Warning!!!

Do NOT store or use gasoline or any other flammable vapors and liquids in the vicinity of this or any other appliance.

FOR YOUR SAFETY: If you smell gas:

- 1. Shut off gas to the appliance**
- 2. Extinguish any open flames**
- 3. If odor continues, immediately call your gas supplier.**

Assembly Instructions for Patio Comfort Natural Gas Patio Heater Model NPC05

Please be sure to read all instructions thoroughly before attempting to assemble or use your Patio Comfort Natural Gas outdoor infrared patio-heater. Before using your heater please read the safety warnings and safety tips. This is a gas-burning appliance that gets extremely hot at the emitter grid. If you have any questions about the final assembly, connections to the fuel source, leak testing the fittings and connections, operation, or function of this appliance please contact your selling dealer or a qualified gas service technician or local natural gas public utility before attempting to operate this appliance.

We have tried to make the assembly of your Patio Comfort Natural Gas heater as simple as possible while maintaining the highest levels of safety and performance.

The installation of this product must comply with local codes or authority having jurisdiction. In the absence of local codes the installation must comply with the ANSI Z223.1 1984 entitled the "National Fuel Gas Code." In Canada, in the absence of a local building code requirement it must comply with the National Standards of Canada CA/CGA-B149.1 & 2 M86.

Your Model **PC-NG** base has been pre-assembled at the factory. The base assembly includes a heavy cast-iron ballast. Under no circumstances should the ballast weight be removed from the base or altered in any way. This ballast weight provides for added safety and stability. Your heater should not be operated in rain, high winds, or dusty conditions. In high wind areas you might want to remove the reflector to minimize the potential danger of the heater blowing over when not in use. Infrared heaters, or any outdoor gas burning appliance, are not designed to operate in windy conditions over 5 – 7 MPH.

Step 1: Lay base on floor or sturdy table with socket assembly in vertical upright position. Slide the 66" long stainless steel or painted post with rectangular access hole at the bottom of the post over the round welded vertical socket on the base.

Align the post holes at the bottom of the post with the holes in the vertical socket assembly. (See Figure #1)



Figure #1

Step 2 A:

Slide 3" Vinyl sleeve down post. Align the holes in the socket with the post and vinyl sleeve. Insert lock washer, flat washer, and screw into four holes. (See Figure #2 A)



Figure 2A

Step 2 B.

Securely tighten the four stainless steel screws with flat washers and lock washers (lock washer is installed first against post and then flat washer) at post to socket connection. (See Figure #2 B)



Figure #2B

Step 3:

Slide 3" diameter stainless steel slip collar over post. The slip collar should now be at the bottom of the post/socket assembly. The slip collar is intended to cover the fasteners and vinyl sleeve. (See Figure #3)



Figure #3

Step 4:

Slide decorative cover down the post over slip collar. Be careful, this piece has relatively sharp metal edges. (See Figure #4)



Figure #4

Step 5:

If the 3/8" x 3/8" flared brass fitting is screwed into the shorter feed line hose please remove it at this time and attach this fitting at the base of the heater head. Tighten securely. Do not use any pipe sealant at this brass to brass connection. Do not over-tighten. (See Figure #5)

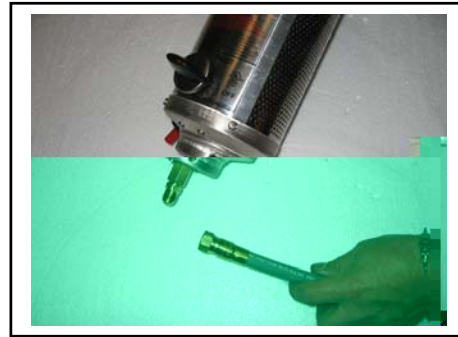

Figure #5

Step 6:

Insert shorter feed line hose in through rectangular access hole at the bottom of the post and feed it out the top of the post. Make sure end of hose and regulator feed line assembly is visible through rectangular access slot at bottom of post. This assembly has been pre-assembled for you and leak tested. Just to be safe, we will ask you to leak test and double check all fittings before using your new heater. (See Figure #6)



Figure #6

Step 7:

Secure head to feed line at this time. Be sure the 3/8" x 3/8" flare brass fitting is tight where it connects to the fitting at the base of the heater head as well as at the hose swivel fitting.. No sealant is required at these fittings. Do not over-tighten. Brass to brass is an excellent connection. Do not secure head to post at this time.



Figure #7

At this point we need to stop assembling the heater and test for any possible gas leaks in the regulator assembly and head to feed line connection. In order to achieve the leak testing we must attach the twelve-foot hose and couplers to the gas supply. If you are not comfortable either hooking up the valve at the gas supply line or leak testing the unit you should contact a licensed plumber, gas technician, or public utility.

Step 8:

- 1) Since there are a variety of possible gas supply configurations our directions can only be general in nature.
- 2) First, shut off the flow of gas to the stub.
- 3) This can be accomplished at the stub if you have a shut off on your stub. If not, you will need to shut off the gas at its source to your stub.
- 4) Attach the combination coupler/shut off valve onto your 1/2" gas line. Your line may be larger than 1/2" so it must be reduced to 1/2" in order to attach the shut-off valve. This is a very safe and convenient system so please do not try to modify it in any way,
- 5) Use an approved pipe sealant or Teflon Gas tape to seal the connection from the stub to the shut-off valve. (See Figure #8)



Figure #8

Step 9:

- 1) With gas still shut off. Insert one of the 3/8" male nipple fittings at end of the 12 foot hose into the coupler at the end of the shut-off valve/coupler.
- 2) You can engage and disengage the couplers by just sliding the ring back at the end of the coupler. The male nipple at the ends of the hose should insert and disengage easily.
- 3) The couplers can only work one way. When the unit is not in use you can leave the hose attached to the heater or you disengage the hose set either at the heater or at the fuel supply or at both points. (See Figure #9) Please try to position the hose so that it does not present a trip hazard.



Figure #9

Step 10: (See Figure #10)

Testing For Gas Leaks

- 1) The hose should be properly engaged at the quick disconnect coupler at the post and at the house supply. Please turn the supply of gas ON.
- 2) Using a soapy solution carefully check each and every fitting, quick coupler, and gas connection. Perform the leak test from the valve to your house gas supply all the way to the connections at the post. Also check where the fittings at the feed line hose is attached to the heater head. You should do this with a soapy water solution. There should be no open flames or other sources of ignition near you when performing the leak test.
- 3) **Never do the gas leak test with an open flame!**
- 4) If you see bubbles at any connection you have a leak. Shut off gas at the source. This leak must be remedied before going any further. Please re-tighten leaking fitting and once again check with a soapy water solution. Most leaks are the result of not tightening the fittings adequately.
- 5) If you cannot stop the leak you should shut off the gas immediately at the shut-off valve and re-check your assembly. If you are still having trouble achieving a gas tight connection you should call your Patio Comfort dealer or qualified gas technician. All the of the key fittings and components are high quality brass fittings and have been pre-tested at the factory.



Figure #10

Step 11:

If your unit passes the gas leak test 100% you can now secure the access panel at the bottom of the post with the four self-tapping pan-head screws provided. (See Figure #11)



Figure #11

Step 12:

Before the last assembly step of securing the head to the post, align the head and post and the gas inlet to minimize any possible trip hazards. Always try to position your heater and hose in a way as to minimize trip hazards. (See Figure #12)

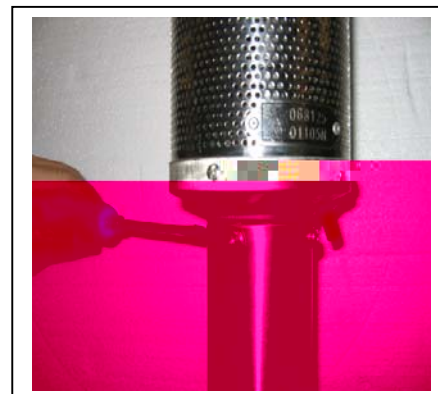

Figure #12

Step 13:

You can now attach the heater reflector with the three 8 mm flat washers and wing nuts provided.
(See Figure #13)



Figure #13

Step 14:

Be sure to attach the blue colored protective rubber plug onto the fitting before inserting it into the gas inlet in the post. The blue plug is designed to keep insects, dust, debris, moisture, and other contaminants out of the feed line, valve assembly, and pilot assembly.

(See Figure #14)



Figure #14

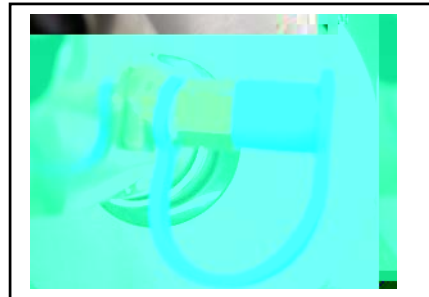

Figure #15

Always be sure to use the dust plug when the heater is not in use.
(See Figure #15)

Please Note:

The end of the hose set that attaches to your home natural gas supply also has a quick disconnect coupler and state of the art shut-off safety valve for your safety and convenience. As an added feature when the "ON and OFF" black control knob on the shut-off valve is in the "ON" position you cannot inadvertently remove the hose from the coupler while the heater is in operation.

(See Figure #16)



Figure #16

This hose, coupler, and shut-off valve assembly comply with all UL standards. DO NOT attempt any modifications to this hook-up.

You have now finished the assembly of the heater. We have tried to design your Patio Comfort heater with the finest materials and safety systems available. Please do not try to modify any part of the product, the feed line assembly, natural gas regulator, or quick disconnect connections.

These are high quality components designed to provide you with maximum convenience and flexibility and more importantly to maximize the safety to you and your family.

Our unique double quick connect system allows you to safely detach the hose set from the heater when not in use. If your dealer has not included this hook-up kit with your heater go back to the dealer and insist that they provide it to you. The hose kit is an integral part of the heater and will add greatly to the safety and convenience of the product.

!!!! Remember any hose can be a potential trip hazard and should be positioned in a way where it presents the least potential trip hazard. The hose can be easily removed from the heater using the quick couplers included. Never attempt to move the heater while it is in operation.

Before using your heater for the first time please review the following:

!!!! NEVER RUN THIS APPLIANCE ON PROPANE FUEL OR ATTEMPT TO CONVERT IT TO PROPANE OR LIQUIFIED PETROLEUM FUELS. THIS HEATER IS ONLY DESIGNED TO BE OPERATED ON NATURAL GAS.

THIS PRODUCT CANNOT BE CONVERTED TO PROPANE GAS.

Please keep in mind that every time you connect your heater for the first time and every time you reconnect the 12-foot hose to the heater you must first bleed the air from the fuel feed line and hose. This is done by turning on the gas at the source and turning the valve at the heater to the "PILOT" position.

You may need to depress the valve control knob on the heater in the PILOT position for at least one to two minutes to bleed the air before attempting to light the PILOT light with the ignitor.

The safety pilot system has a very small orifice size and it may take up to two minutes to bleed all of the air out of the line. After purging the air, depress the igniter button and you will hear the pilot light. You can also visually see it through the vents in the base of the heater head or through the small access hole with cover plate on the base of the heater head.

A FEW WORDS ABOUT NATURAL GAS:

First of all, natural gas is a safe, clean, convenient, and cost-effective fuel. You will never have to worry about running out of fuel for your natural gas heater in the middle of an outdoor event.

The heater is set to operate 4.5" W.C. No attempt should be made to modify any of the components included with your Patio Comfort natural Gas heater.

In most areas of the U.S. and Canada, natural gas pressure in residential settings is adequate to fuel patio heaters, outdoor gas grills, gas lights, pool heaters, etc. In some of the older areas in the West, parts of New England, and the Mid-Atlantic areas gas pressures may be too low to allow for this product (or any natural gas appliance) to operate at its full performance levels. If you feel that this may be the case in your home you should first check with your local natural gas public utility. You may have to run a larger fuel pipe to adequately power this and possibly other backyard cooking, heating, or decorative natural gas burning appliances. If you have inadequate gas volume using multiple appliances at the same time may impact the heat output or performance of the various appliances.

We have designed this heater to provide you and your family with many years of use. If you have any questions whatsoever about the assembly, installation, or use of this product please contact your selling dealer or distributor before using this product.

Placement of the Heater

Your *Patio Comfort* outdoor patio heater is designed for use as temporary comfort heating for your outdoor patio, outdoor decks, outdoor spa areas, pool areas, and other outdoor areas with plenty of fresh air.

The heater is NOT designed, approved, or intended for indoor use or enclosed area use such as a garage, commercial building, basements, tents, ice fishing tents, prefabricated buildings or enclosures or other enclosed areas.

The heater is also not designed for use on moving objects or vehicles such as houseboats, yachts, travel trailers, boats, or other moving devices or vehicles.

The minimum clearances from combustibles must be maintained at all times. We recommend the heater be no closer than 27 inches from any combustible vertical or horizontal wall or have any combustible material within 20 inches of the top of the reflector.

“Combustibles” include Lattice, Wood, Plants, Umbrellas, Canopies, Awnings, or other Combustible Materials



These minimum clearances from combustible materials must be maintained at all times when the patio heater is in operation.

The heater must always be used on firm, level, and stable ground. **Never move the heater while it is in operation.** Never try to hook up multiple feed line hoses together.

WARNING: Never operate heater in an explosive atmosphere and be sure to keep unit away from where gasoline or other flammable liquids or vapors are stored or used.

Lighting Instructions

Before turning on the natural gas fuel supply, visually inspect the hose assembly for evidence of excessive abrasion, cuts, cracking, animal damage, or unusual wear and tear. If the hose leaks do not attempt to use the heater, replace the hose immediately. Only use replacement hoses and other parts as specified by *Patio Comfort*.

Before Lighting

If attempting to relight a hot heater, always wait at least five minutes. The main heater components such as the emitter grid, gas hook up, and pilot assembly should be checked at least every two years by a qualified service technician or immediately if you feel the appliance is not working properly.

To Light Heater

- 1) Be sure the control knob on the heater head is in the “**OFF**” position.
- 2) Turn the shut off valve at the house connection in a **counter-clockwise** direction to open. Be sure the quick connect couplers at the heater post and end of the hose at the shut-off are fully engaged and tight. If the couplers are not properly engaged, no gas will flow to the heater.
- 3) Gently depress the control knob on the control panel and rotate it counter clockwise to the “PILOT” position.
- 4) ***This is very important!*** Gently depress the control knob and hold the control knob to begin the flow of gas to the burner pilot assembly. Depress the control knob in the “PILOT” position for up to **2 minutes on new installations or reconnected hoses.** This is how long it might take for the air to be purged from the hoses and feedline delivery system. It will take less than 10 seconds for regular relighting. **Do NOT continually press on the igniter while you are purging the line.** This will only cause premature wear and tear on the ignition and weaken the charge created by the piezo ignition. Occasionally depress the igniter and you will hear when the pilot light ignites.. You can also see the pilot light through the pilot access port that has a small rectangular cover at the base of the heater head. This is essentially the same safety system that you have on your water heater. Please be patient with this process. You can also hear the pilot light when it lights.
- 5) Once the pilot is lit, continue to depress the control valve for about 20 seconds or until the pilot flame remains lit after the control knob is released.
- 6) The burner may now be turned on to the full “**ON**” position for maximum heat output or it may be turned back to the “PILOT” position to reduce heat output and fuel consumption. If you turn the control knob all the way back to the “PILOT” position, the main burner will go off and the pilot flame will remain lit. You can now re-ignite the main burner directly from the “PILOT” position. On the first use, a little smoke is to be expected. This is machining oils being burned off.

The heater is designed to be operated in the full “ON” position only. Turning the heater down will result in incomplete combustion and sooting of the burner and very low heat output. You can immediately re-light the main burner when the standing pilot is on.

If you turn the heater off and then have to re-light:

- 1) Turn control knob to the “OFF” position.
- 2) Wait at least **FIVE minutes** before attempting to relight heater. The safety system built into the heater will not allow you to immediately re-light the heater directly from the “OFF” position. Please do not try to defeat this safety system.
- 3) **Repeat starting with STEP #6. You should not have to wait more than few seconds to re-light the “PILOT” light and then ignite the main burner.**

To Turn Off or Shut Down Heater

- 1) Turn the control knob in a clock-wise direction to the “OFF” position. You may hear a slight popping sound when the main burner shuts down. This is normal.
- 2) Turn the black shut off knob at the valve at the house supply in a clock-wise direction to turn it off. You can now disconnect the hose at the house gas or heater post if desired.

When your heater is not in use, you can safety disconnect your hose set.

Storing your Heater

When storing your heater you can either leave your hose set connected and wrapped around the heater post or you can remove it completely. **If you disconnect the hose at the heater, please always use the blue protective rubber caps to keep insects and other debris out of the feed line and internals of your heater. Dirt, debris, or insects can impede or completely obstruct the flow of gas to your heater and negatively affect the operation of the heater.**

Store your heater in an upright position in an area sheltered from inclement weather such as rain, snow, sleet, hail, dust storms, and other blowing debris.

Patio Comfort makes a cover available to protect the burner head. We strongly recommend using our cover when your heater is in storage or not in use. The Item number for the cover is “PCC-1”. This cover is available from your *Patio Comfort* retailer or distributor. The cover will help protect the heater head from moisture as well as insects. **CAUTION: Be sure heater is cool to the touch before using the cover.**

Spider and Insect Warning

Spiders and other insects are attracted to the smell of unburned natural gas and propane. This is the case for outdoor heaters, gas grills, gaslights and torches, pool heaters, and other outdoor gas burning products. The webs and obstructions created by these insects can cause conditions that may damage the appliance or

render it unsafe for proper use. You should inspect the burner at least once a year or immediately if any of the following conditions are present when operating the heater: Do not try to use heater if venturi or orifice is blocked.

1. The odor of gas in conjunction with extreme yellow tipping of the burner flame.
2. The emitter grid does not glow evenly or reach proper operating temperatures.
3. The burner makes a popping or roaring noise.
4. If a blockage is present, clean the orifice or burner immediately before trying to light heater.

If you feel uncomfortable working on the heater, please contact your servicing dealer or distributor for the name and number of a qualified service technician.

Cleaning & Maintenance

Your heater has been produced from highly weather resistant materials and only requires minimum cleaning and maintenance. **Cleaning must be performed when the heater is cold.** Your patio heater will last longer if it is cleaned and maintained properly. It is very important that the air required for the combustion process is not blocked going to the burner. Orifices, burner venturis, vents, and other openings must be kept free of dirt and spider webs. You can use a can of pressurized air to clean debris from the emitter grid. It can also blow off any dust inside the emitter grid. If your pilot orifice or main burner orifice becomes clogged, corroded, or blocked you will need to remove the reflector and emitter grid to clean these components.

Stainless steel does not “rust,” however varying atmospheric conditions; areas with acid rain, or beach and ocean areas with heavy misty conditions may leave brown deposits, surface rusting, or surface oxidation on the heater. This is to be expected of any stainless steel product used outdoors. We recommend washing the outer stainless steel or painted surfaces components such as the post and decorative cover and perforated material around the lighting instructions with a mild detergent solution and immediately wiping it clean with a dry soft cloth. The stainless steel can be expected to darken, possibly distort, and discolor around the heater head and pan as it sustains extreme temperatures. This is normal and to be expected with any outdoor gas heating or cooking appliance that operates at high temperatures.

Never use a cleaning agent that is flammable or corrosive near the heater head. There are several excellent stainless steel cleaners available through your local dealer for our stainless steel models. If you do not find a suitable local source call us directly and we can provide you with an excellent cleaner. Never spray any cleaning product on the emitter grid or burner area. Never clean the heater when it is operating.

The burner ports must also be kept clear so that the burner burns evenly and the flow of gas is not restricted. If the heater is not performing adequately, it will be necessary to remove the emitter grid assembly to check the burner and burner venturi.

In a salt air or ocean environment, corrosion and rust occurs at a far greater rate than in non-ocean areas. You will need to more frequently check for corrosion and replace parts as required. The best protection for the critical heater head is a *Patio Comfort* cover that has been specifically designed for your heater. The cover can be purchased at your *Patio Comfort* dealer. A stainless steel protective cleaner such as PGS Stainless Steel Cleaner will help protect the finish of all stainless steel components.

NATURAL GAS HEATER TROUBLE SHOOTING GUIDE

If you are having this problem:	If this condition exists:	You will need to do the following:
<p>The pilot light won't light</p>	<ol style="list-style-type: none"> 1) Shut-Off Valve at House gas is off. 2) Quick Disconnect couplers are not engaged properly. 3) Air or debris in fuel lines. 4) Igniter is not sparking. 	<ol style="list-style-type: none"> 1) Open shut off valve. Turn black knob on valve in counter-clockwise direction 2) Check quick disconnect/nipple engagement. Pull back sleeve and engage fully. 3) Purge air by holding control knob at "PILOT" position for at least two minutes until you smell gas. 4) Use match to light pilot through access hole at base of heater head. Seek service or check igniter wire connections. Replace igniter or wire if required.
<p>The pilot, after initial lighting, will not stay lit</p>	<ol style="list-style-type: none"> 1) There may be a leak in the system. 2) Dirt build-up around pilot orifice. 3) Thermocouple is not operating properly. 4) High wind condition blowing out pilot flame. 	<ol style="list-style-type: none"> 1) Check connections at hose to feed line and feed line to heater head. 2) Clean pilot orifice with compressed air. 3) Depress Knob in "Pilot" position for full 30 seconds. Remove emitter grid and replace thermocouple. Use only Patio Comfort thermocouples and parts. 4) Put heater in more protected location. Do not use heater in winds in excess of 10 MPH. Do not use heater in high wind conditions, rain, or at temperatures below 40° F.
<p>Main burner will not light</p>	<ol style="list-style-type: none"> 1) Gas Pressure is low. 2) Blockage in main burner orifice. 3) Control knob is not in "ON" position. 	<ol style="list-style-type: none"> 1) Check pressure of fuel line. Heater requires minimum 6" W.C. to shut off. 2) Clear Spider web or other blockage. 3) Turn knob to "ON" Position.
<p>Burner flame is low or emitter grid does not glow evenly. Please note: Bottom 1-2" of emitter grid normally does not glow.</p>	<ol style="list-style-type: none"> 1) Gas pressure or gas volume is too low. Control knob not set to full "ON" Position 2) Heater is not on a level surface 	<ol style="list-style-type: none"> 1) Have gas pressure checked by gas technician. Turn knob to "ON". 2) Reposition heater onto hard and level surface.
<p>Carbon build up on emitter grid or thick black smoke coming from head</p>	<ol style="list-style-type: none"> 1) Dirt or film on reflector or emitter grid. 2) Unit is not being operated in full "ON": 3) Blockage in burner head, venturi tube, or orifice. 	<ol style="list-style-type: none"> 1) Gently clean reflector or emitter. Clear spider webs or debris. 2) Heater must be operated in FULL "ON" setting. 3) Remove burner and check for burner ports for blockage.

Important Warnings and Safety Points!!!

For Your Safety:

If you smell gas:

1. Shut off gas to the appliance
2. Extinguish any open flame near the appliance
3. If odor continues please call your gas supplier

For Your Safety:

Do not store or use gasoline or other flammable vapor and liquids in the vicinity of this or any other appliance.

Warning!!!

Improper installation, adjustment, alteration, service, or maintenance can cause physical injury or property damage. Read the instructions thoroughly before installing, operating, or attempting to service this appliance.

Danger!!!

Some Important Heater Safety and Use Precautions:

Failure to comply with the precautions and instructions provided with this heater can result in death, serious bodily injury, and property loss or damage from hazards of fire, explosion, burn, asphyxiation, and or carbon monoxide poisoning. Please be sure you understand all operating instructions before attempting to operate or service this or any appliance.

This appliance is designed and approved for outdoor use only (outside of any enclosure). Always be sure there is plenty of fresh air when the heater is in use.

- Always use extreme caution while heater is in operation. Alert both children and adults to the fact that the emitter grid will generate extremely high surface temperatures (1600 degrees plus) and will cause burns if touched if the heater is in operation. Wait at least thirty minutes before touching any hot portion of heater. Above the control knob.
- Always maintain at least a 27" inch clearance in all directions from any combustible material.
- Please be sure heater is on a hard level surface. Be sure ballast weight is assembled into base to prevent possible tipping. **Never move the heater while it is in operation.**
- All leak tests should be done with a soapy solution and **NEVER with a match or open flame device.**
- Do not attempt to use the heater if wind conditions exceed 8 miles per hour. It is possible that the high wind will blow the burner flame out. Position the heater so that it is not directly exposed to water spray, rain, and or dripping water or winds.
- Do not attempt to paint reflector, emitter grid, or any portion of the heater control assembly.
- Do not attempt to modify or alter the natural gas regulator that is included with your heater. It is preset at the factory for 4.5" water column. This is required for proper operation and safety.
- The heater is equipped specifically for use with Natural Gas.
- Please keep water and sprinklers away from heater especially while in use.

- Do not use in a combustible atmosphere. Keep the heater away from areas that have flammable liquids, gasoline, vapors, or explosives stored or used. Do not use the heater inside your garage or other indoor work areas.
- Do not hang clothing or any other combustible materials on or near heater when it is in operation.
- Young children and pets should be closely supervised when the heater is in operation.
- Never hook up the heater to an unregulated Natural Gas supply line.
- Do not touch the emitter grid or reflector unless the heater has been turned off and cooled for at least 40 minutes.
- To avoid the possible risk of burns or possibly catching clothing or other combustible materials on fire, do not touch the heater anywhere close to the emitter grid or burner assembly while the heater is in operation
- Please do not attempt to clean your heater with combustible or corrosive materials.
- Minimum inlet pressure cannot exceed 1/2 psig.
- Do not attempt to alter the heater in any manner whatsoever. The unit has been designed to provide you with many years of trouble free service if maintained per our recommendations.
- Inspect heater before each use. If you find a damaged part, please replace the part with a genuine *Patio Comfort* part before using the appliance.
- Do not attempt to use your heater without the proper factory supplied hose and regulator. Use of unauthorized replacement parts may result in damage to the unit, cause improper operation, and performance, and may cause property damage or bodily injury.
- The purchaser assumes all risk in the assembly and operation of this appliance. Failure to follow these warnings and instructions can result in severe personal injury, property damage, or death.
- **Do NOT attempt to move the heater while it is in operation.**
- Use this appliance in accordance with local codes and safety ordinances. In the absence of local codes refer to ANSI standard Z223.1
- If you have any questions whatsoever about the assembly or operation of this product please contact your authorized *Patio Comfort* retailer or call us directly at 949-474-3070 or E-mail aeicorp@sbcglobal.net. This product has been designed and constructed to provide you and your family with many years of safe, convenient, outdoor comfort.

WARNING: Chemicals known to the State of California to cause cancer, birth defects, or other reproductive harm are created by the combustion of natural gas, propane and other fossil fuels.

SERVICE AND WARRANTY INFORMATION

To learn how to service and acquire replacement parts, first contact your selling dealer/distributor or call us directly at 949-474-3070 or e-mail us at aeicorp@sbcglobal.net for assistance. Please provide us with the model number and serial ID number for best possible service and support. Please be sure to fill-out your Patio Comfort Warranty card so that we can have you on file. We will not use this information for any marketing activities.

Our company has been in the quality leisure gas appliance business since 1966 and we want to be sure that you are happy with our products and support services.

Be sure to use only genuine *Patio Comfort* replacement parts for your heater. Use of unauthorized parts or modification of our parts will void the heater warranty and could create personal injury or property damage.

Always be sure that your heater is cool to the touch before attempting any service or maintenance procedures.

Warranty

Patio Comfort will cover:

Patio Comfort heaters are warranted against any defects in parts for a period of **1 year** from the date of purchase with original purchase receipt. We will warranty against structural defects all external stainless steel components (posts, bases, hardware, slip collars, & decorative covers) for **5 Years** from date of purchase. Emitter grid is not included. This part has a one-year residential use warranty.

This ONE-YEAR consumer warranty is only applicable for consumer or residential applications. We offer a 120-day warranty protection for heaters that are used in a commercial or rental application. Commercial warranty does NOT cover emitters, ignition, burners, or component failure caused by abuse, transportation, or misuse.

This warranty is valid from the original date of purchase and is transferable. Please keep your original sales receipt or invoice. Proof of purchase is required to obtain warranty replacement. *Patio Comfort* retail dealers or distributors do NOT have the authority to modify, alter, or in any way change the product or the terms and conditions of this warranty.

We will NOT cover the following:

- Freight charges to our facility in Irvine, California (We will pay all return freight costs)
- Assembly or installation costs
- The repair of rented heaters
- Improper assembly or improper hook-up
- Damage or repairs that result from debris in the unit, spiders, or other insect nesting
- Damage due to weather conditions or lack of proper maintenance and cleaning
- Normal maintenance, cleaning, or burner adjustments
- Cleaning or periodic general maintenance
- Shipping or freight damage
- Service provided by an unauthorized agency or service person or use of unauthorized parts.
- Overtime, weekends, and holidays
- Service visits to correct improper assembly or installation.
- Damages caused by abuse, lack of normal cleaning and maintenance procedures, improper assembly, accident, acts of nature, vandalism, transportation, or alteration.
- We will not repair rented heaters that have been repurchased for residential use
- We will not cover normal wear and tear such as discoloration to the finish, corrosion, surface rust, normal wear and tear, oxidized surfaces, surface scratches, chips, abrasion, or fading from exposure to sunlight or other atmospheric conditions.

Your Legal Rights

- **CONSEQUENTIAL DAMAGES, INCIDENTAL DAMAGES, OR EXPENSES INCLUDING DAMAGES TO PROPERTY. SOME STATES/PROVINCES DO NOT ALLOW THE EXCLUSION OR LIMITATION OF INCIDENTAL OR CONSEQUENTIAL DAMAGES, SO THE ABOVE LIMITATION OR EXCLUSION MAY NOT APPLY TO YOU. WE WILL NOT BE RESPONSIBLE FOR ANY COSTS RELATING TO LOST REVENUE, BUSINESS INTERRUPTION, OR ANY LEGAL THEORY UPON WHICH ANY CLAIM MAY BE BASED.**
- **PURCHASER ASSUMES ALL RISK IN THE ASSEMBLY AND OPERATION OF THIS APPLIANCE. FAILURE TO FOLLOW THIS MANUAL'S WARNINGS AND INSTRUCTIONS CAN RESULT IN SEVERE PERSONAL INJURY, DEATH, OR PROPERTY DAMAGE**

This warranty is for all *Patio Comfort* heaters purchased and used in the 50 US states, The District of Columbia and Canada. This warranty applies even if you should move during the warranty period. Should you sell the product during the warranty period the warranty protects the new owner as well. This warranty provides you with specific legal rights. You may also have other rights that vary from state to state.

How to obtain service:

For most product, missing parts, or assembly related problems your selling dealer can provide you with help. The product has been designed to be as trouble-free and maintenance free as possible and requires minimal assembly. Should you have a problem with missing parts please contact your selling dealer or contact us directly at 949-474- 3070. We exercise extreme care in the assembly and manufacturing process, but we know errors can be made and we want to take care of them as quickly and painlessly as possible.

Since product improvement is an ongoing process, we reserve the right to change this product's materials, internal components, specifications, or design without notice.

We know that you and your family will enjoy your *Patio Comfort* heating product for many years to come and that it will be a welcome addition and important ingredient to your outdoor entertainment and activities.

Patio Comfort Heater Warranty Registration Form

Please return this warranty registration card within 10 days

Congratulations on purchasing a **Patio Comfort Model NPC05** Outdoor Heater. To ensure that you'll get all of the warranty protection that comes with the purchase of this fine product please fill out the Warranty Registration Form and send it back to us **within 10 days of purchase**.

Rest assured that your registration information is for our information and tracking only and will NOT be used by any other company or organization. Appliance manufacturers are required to keep detailed design, component, production, testing, and manufacturing information in the event there is ever a defective part or we need to quickly contact our customers regarding any added safety information regarding our products. Your cooperation in this tracking system is extremely important. Please fill out the information below as completely as possible.

Last Name _____ **First Name** _____ **Middle Initial** _____

Date Of Purchase Month _____ **Day** _____ **Year** _____

Model of Heater _____ **Fuel Type** **NATURAL GAS**

Serial Number of Heaters Purchased:

Name Of Selling Dealer _____

Address Of Selling Dealer _____

Your Home Address _____ **State** _____ **Zip** _____

E-mail address (optional) _____

Thanks again for your purchase please mail this today so that we can activate your warranty information.

Please mail to:
AEI Corporation
C/O Warranty Registration Department-Patio Comfort
PO Box 16097
Irvine, California
92623-6097